

**Time: 3 Hours**

**Mark: 100**

### **Instructions to Candidates**

- 1 Check that the following materials have been provided:
  - One piece 240mm long, planed to 40mm wide and 30mm thick.
  - One piece 150mm long, planed to 30mm wide and 30mm thick.
  - One piece 120mm long, planed to 30mm wide and 24mm thick.
  - One piece 160mm long, planed to 40mm wide and 30mm thick.
  - Two name tags. One to be attached to the work piece and the other one to be tied to the bag.
- 2 A second supply of wood is Not allowed. If you make a mistake, do your best to work as near to the details given in the drawing as possible. All pieces of wood should be finished to the correct lengths and their ends neatly trimmed with a plane.
- 3 Attempt to finish all parts of the test.
- 4 You may use any of the ordinary hand tools but the use of adhesives, glass paper, files, rasps and scappers is not allowed.
- 5 Additional marks may be gained if the work is rightly cleaned off with a finally set smoothing plane before being finally assembled.
- 6 Write your name and examination number boldly and clearly on each of the pieces of wood in capital letters and number 6mm high. Attach a tag with your name in full, examination number, centre number and centre name.
- 7 Assemble your work and put in a polythene plastic bag before handing it to the Supervisor.
- 8 Any dimensions omitted are left to you discretion.

### **Information for Candidates**

- 1 This paper consists of one practical question.

## PRACTICAL TEST

### Instructions to Candidates

The pictorial drawing in **Figure 1** shows a simple movable cloth stand and **Figure 2** shows the orthographic projection of a cloth stand.

You are required to:

- (a) make the portion enclosed in an eclipse.
- (b) join Part A to Part C by means of an appropriate joint.
- (c) apply the shaping as indicated on Part D.

The following pieces of wood, previously planed are to be used:

- Piece A** One piece 240mm long, planed to 40mm wide and 30mm thick.
- Piece B** One piece 150mm long, planed to 30mm wide and 30mm thick.
- Piece C** One piece 120mm long, planed to 24mm wide and 24mm thick.
- Piece D** One piece 160mm long, planed to 40mm wide and 30mm thick.

### Working Procedure

- 1 Mark out all the joints and cut them.
- 2 Join Part A to B by means of plain single dovetail joint.
- 3 Join Part A to Part B by means of a through Bridle joint.
- 4 Join Part A to Part C by means of an appropriate joint .
- 5 Apply the shaping as indicated on Part D.

### Assembly Procedure

Fit the joints. Do not force the joints. Assemble the work, make sure that you dismantle your work before putting them in the bag.

**EXAMINATIONS COUNCIL OF ZAMBIA**

Examination for School Certificate Ordinary Level

**Woodwork**

**6030/2**

Paper 2 Practical Test

Thursday

5 NOVEMBER 2015

**INSERT**

**Time: 3 Hours**

**Mark: 100**

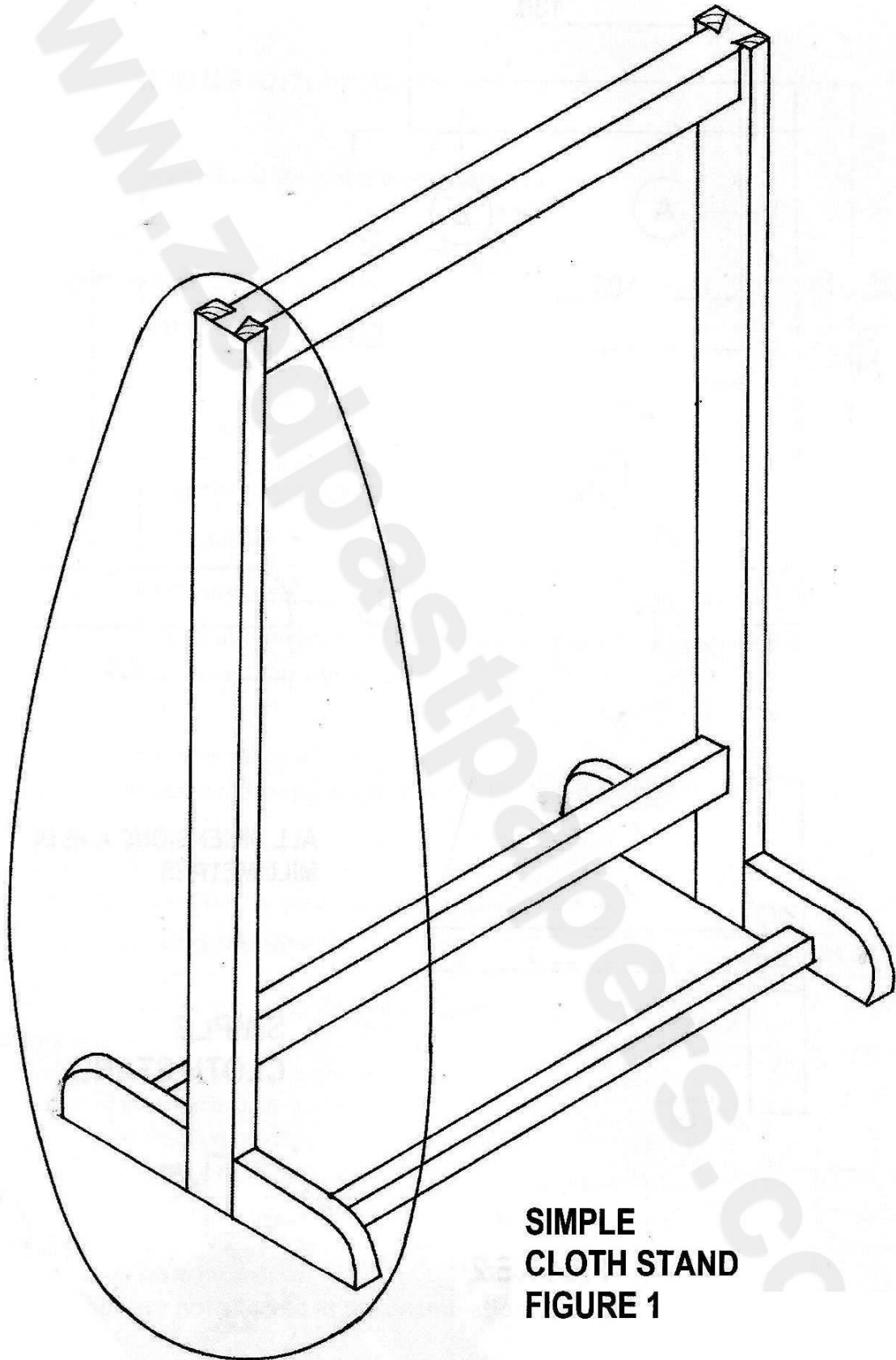

**SIMPLE  
CLOTH STAND  
FIGURE 1**

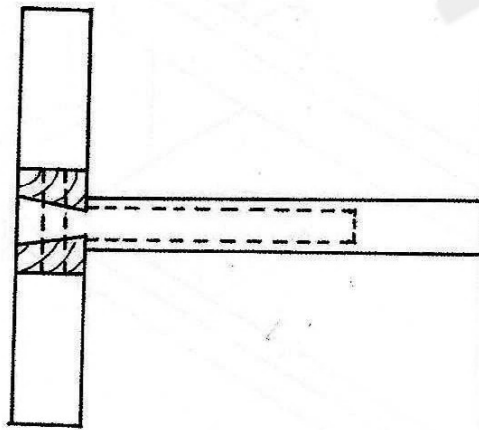
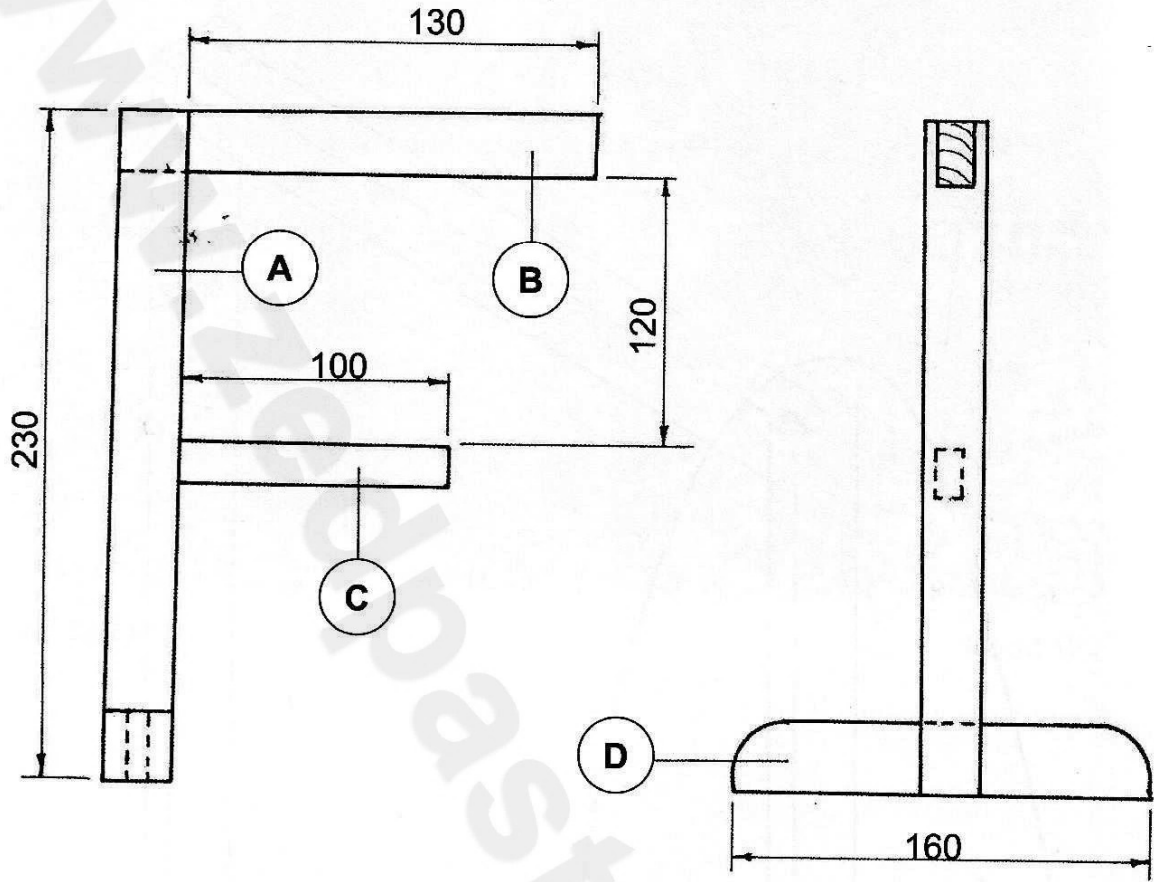

ALL DIMENSIONS ARE IN  
MILLIMETRES

**SIMPLE  
CLOTH STAND**

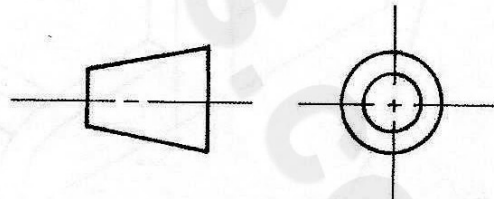

**FIGURE 2**