

EXAMINATIONS COUNCIL OF ZAMBIA

Examination for General Certificate of Education Ordinary Level

Geometrical and Mechanical Drawing

7040/1

Paper 1

Thursday

13 JULY 2017

Additional Material(s):

A2 Drawing paper (1 sheet)
Standard drawing equipment

Time: 2 hours 40 minutes

Marks: 100

Instructions to Candidates

Print your Name, Centre Number and Candidate Number at the bottom right-hand corner of your drawing paper.

There are **eight** questions in this paper. Answer **five** questions.

Answer not more than **three** questions from any one section.

Unless otherwise stated, strictly geometrical methods must be used, solutions are to be drawn in full size and no dimensions are required. All construction lines must be shown clearly, but lines which are parallel to, perpendicular to or inclined at angles of **30°**, **45°** or **60°** to other lines may be drawn without showing construction lines.

Use only one sheet of A2 drawing paper

You may use **both** sides of the drawing paper for your answers.

Information for Candidates

The number of marks is given in brackets [] at the end of each question or part question.

All dimensions are in millimetres unless otherwise stated.

Cell phones are **not** allowed in the examination room.

SECTION A

You may answer **two** or **three** questions from this section.

Question 1

- (a) Construct a regular octagon given that the diagonals are 80mm long. [6]
- (b) Transpose the octagon constructed in (a) above into a square of equal area. [12]
- (c) Measure and state the side of the square. [2]

[20]

Question 2

Figure 1 shows a drawing of a metal template. Construct full size the given template clearly showing all points of tangency.

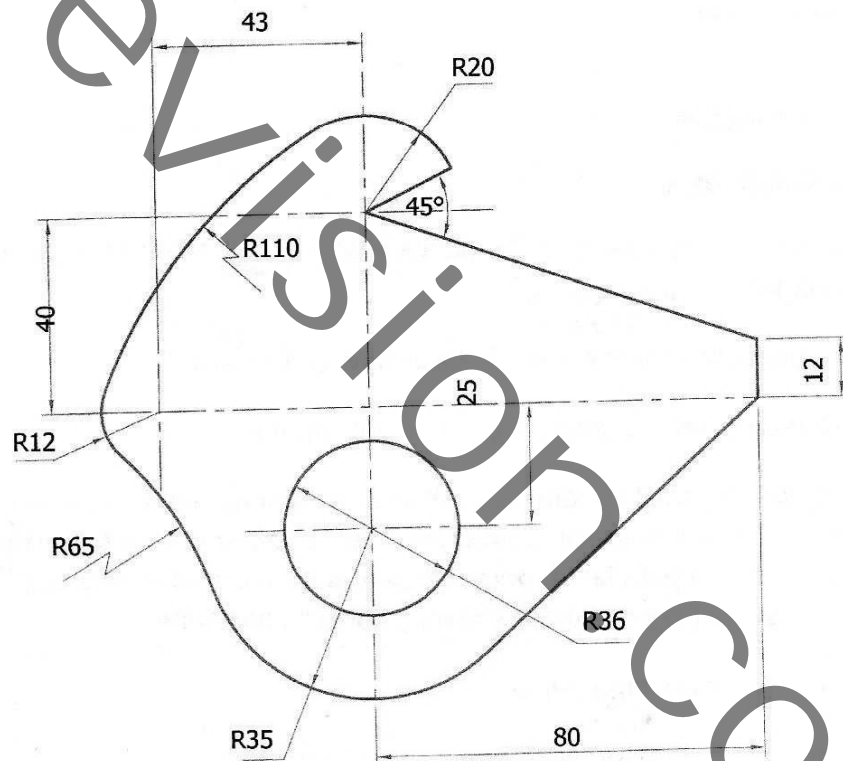

Figure 1

[20]

Question 3

A wheel of diameter 60mm rolls on a flat surface without slipping.

- (a) Plot the locus of point **P** initially in contact with the ground for one revolution of the wheel. [14]
- (b) Construct a tangent at point **T** 40mm from the end of the locus. [5]
- (c) Name the locus drawn in (a). [1]

[20]

SECTION B SOLID GEOMETRY

Answer not more than **three** questions from this section.

Question 4

Figure 2 shows three views of a centre block in **First Angle Projection**.

Do not copy the given views but draw full size an isometric drawing making corner **E** the lowest point. **[20]**

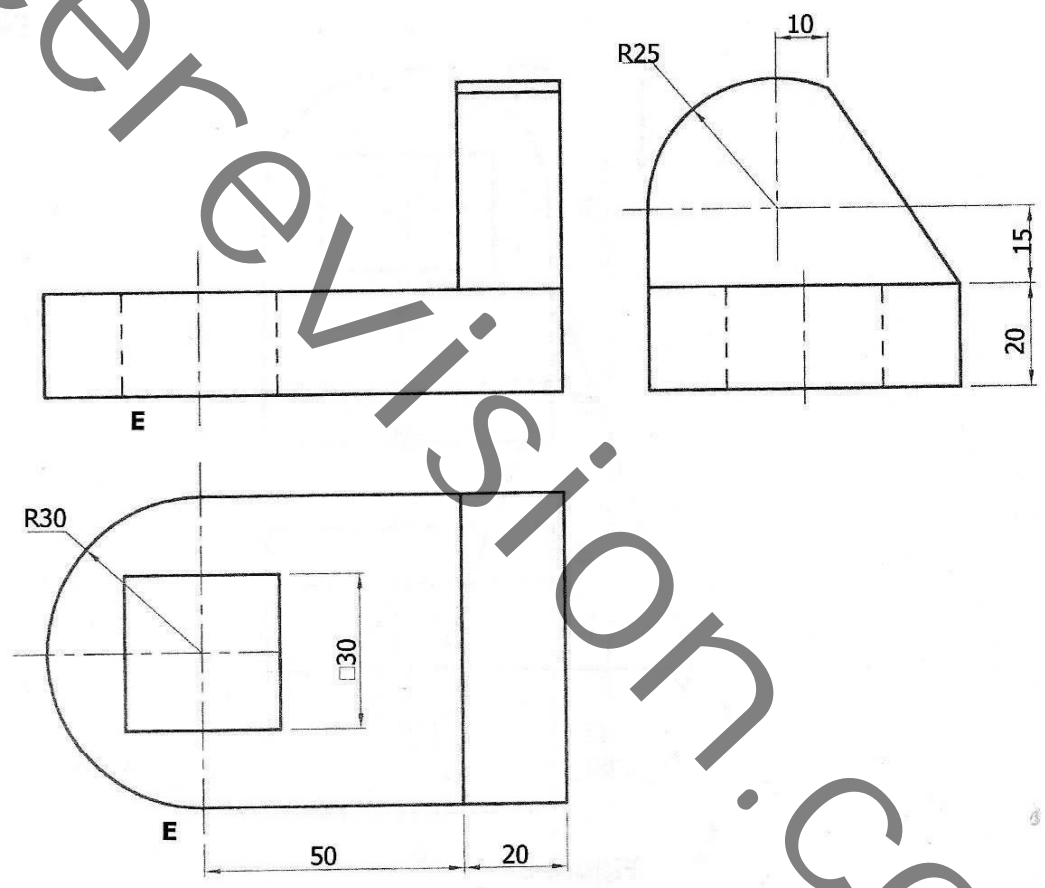

FIGURE 2

Question 5

Figure 3 shows the elevation of a right cone cut by a plane Y–Y parallel to the generator.

(a) Draw the given elevation and complete the plan viewed from arrow **P**. [10]

(b) Draw the true shape of the cut surface. [8]

(c) Name the shape produced in (b). [2]

[20]

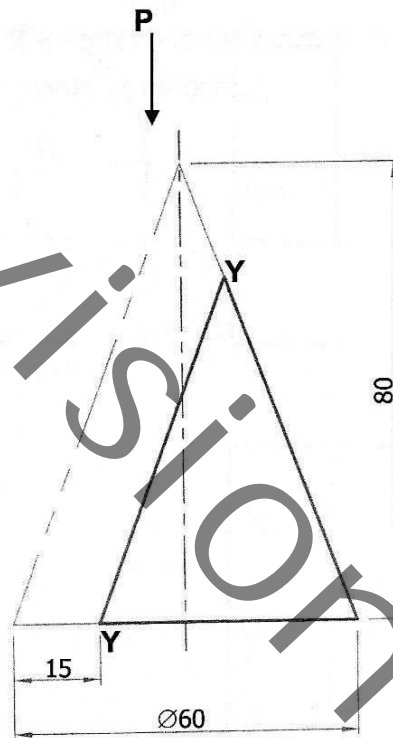

Figure 3

Question 6

Figure 4 shows the plan and elevation of a bracket in **First Angle Projection**.

- (a) Draw the given views.
- (b) Draw an auxiliary elevation viewed from arrow **E**.
NB: Show ALL hidden details.

[20]

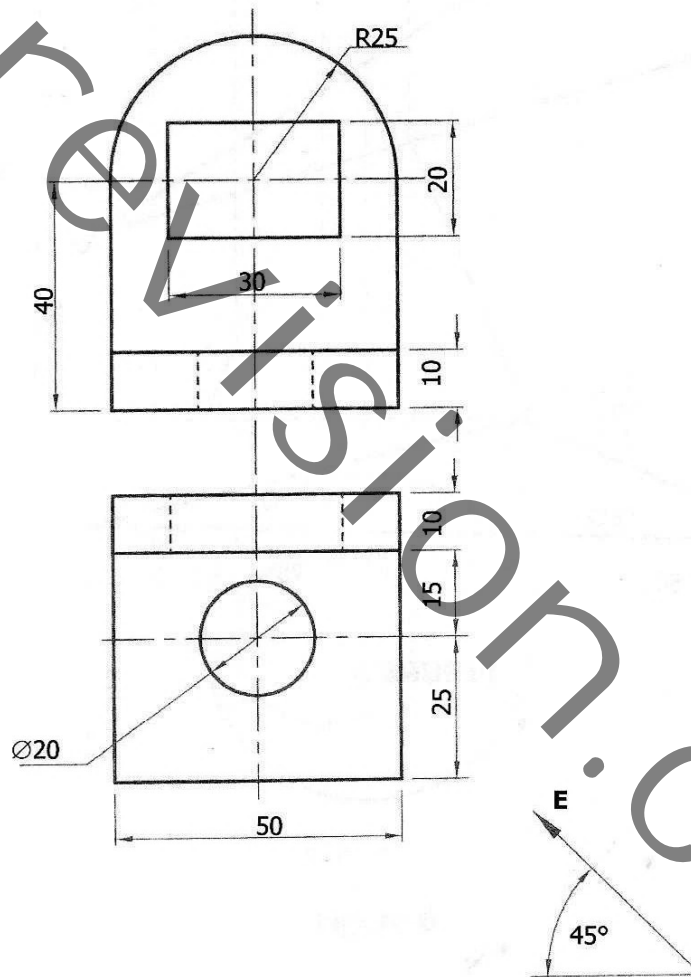

FIGURE 4

Question 7

Figure 5 shows the plan and elevation of a triangular Lamina.

- (a) Copy the given views. [8]
 - (b) Find the true lengths of each side and draw the true shape of the Lamina. [12]
- [20]

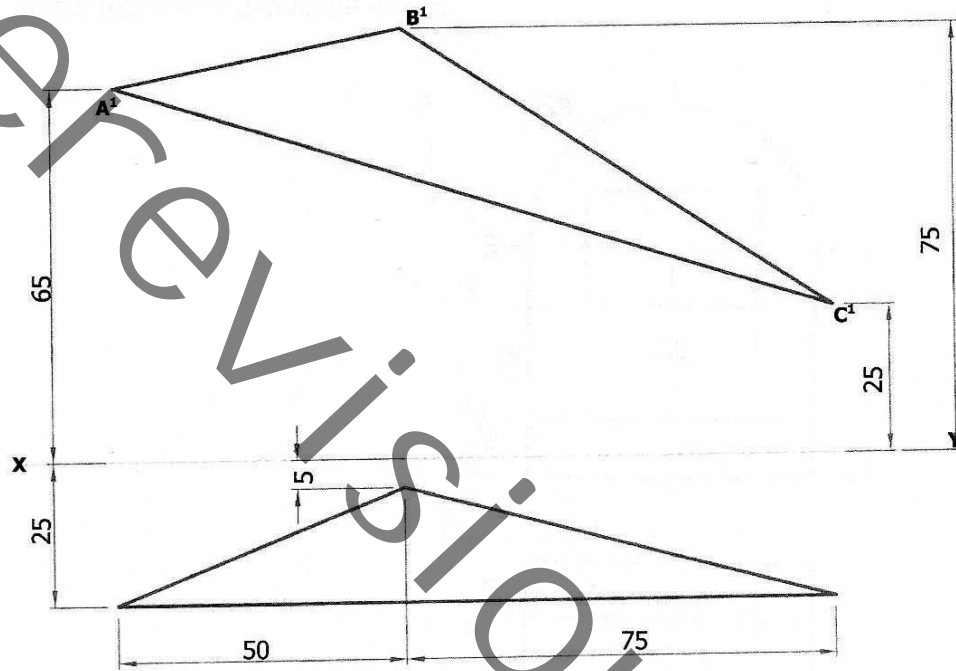

FIGURE 5

Question 8

Figure 6 below shows the Plan and an incomplete elevation of a junction piece between a right cone and cylinder in **First Angle Projection**.

(a) Draw the given views and complete the elevation. [14]

(b) Draw the surface development of the cylinder taking the seam along **P – P**. [6]

[20]

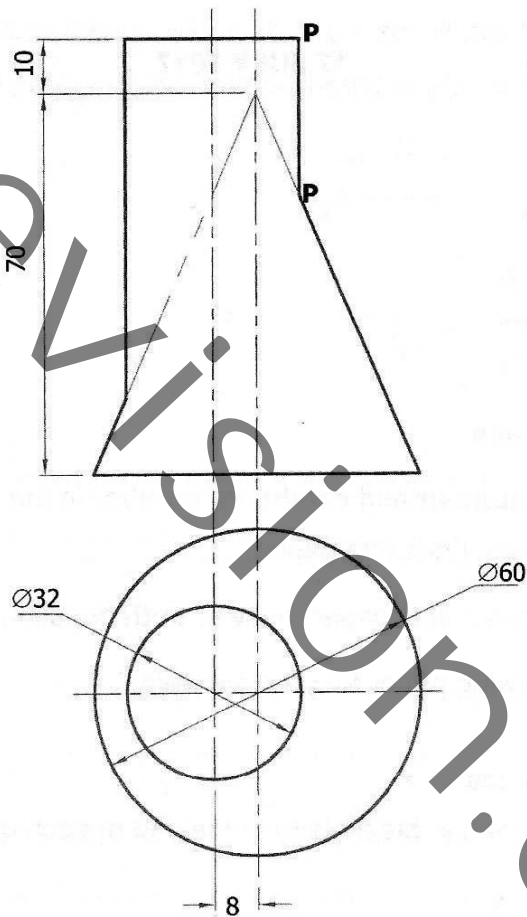

Figure 6