

Candidate Name \_\_\_\_\_

Centre Number		Candidate Number												

# EXAMINATIONS COUNCIL OF ZAMBIA

Examination for School Certificate Ordinary Level

## Mathematics

4024/1

### Paper 1

Thursday

27 OCTOBER 2016

Candidates answer on the question paper

**Additional materials:**  
Geometrical instruments

**Time: 2 hours**

#### Instructions to Candidates

Write your name, centre number and candidate number in the spaces provided at the top of this page.

There are **twenty-three** questions in this paper.

Answer **all** questions.

Write your answers in the spaces provided on the question paper.

If working is needed for any question, it must be shown in the space below that question.

No paper for rough work is to be provided.

**Omission of essential working** will result in loss of marks.

**Electronic calculators and mathematical tables should not be used in this paper.**

**Cell phones are not allowed in the examination room.**

#### Information for Candidates

The number of marks is given in brackets [ ] at the end of each question or part question.

The total number of marks for this paper is 80.

**For Examiner's Use**

1 Evaluate  $8^{\frac{2}{3}}$ .

Answer: ..... [2]

2 Simplify  $3(a + 5) - a(a - 2)$ .

Answer: ..... [2]

3 The diagram below shows a right pyramid with a square base **ABCD** and apex **P**.

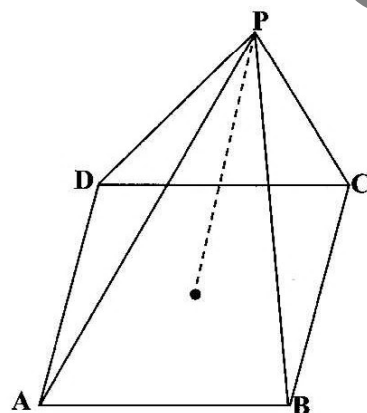

How many planes of symmetry has the pyramid?

Answer: ..... [2]

- 4 Use set notation to describe the shaded region in the diagram below.

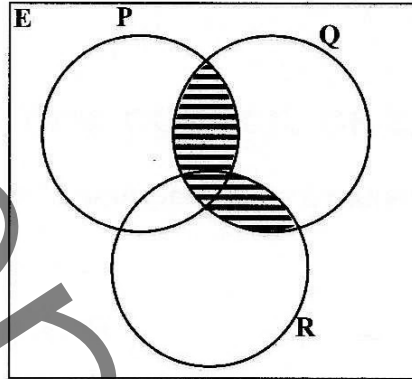

Answer: ..... [2]

- 5 Express  $(-1 \ 2 \ -3) \begin{pmatrix} 5 & -2 \\ 4 & 2 \\ 3 & 1 \end{pmatrix}$  as a single matrix.

Answer: ..... [2]

- 6 On the diagram in the answer space,  $\vec{OP} = p$  and  $\vec{OQ} = q$ . Given that  $\vec{OR} = p + q$ , draw a directed line segment  $\vec{OR}$  on the same diagram.

Answer:

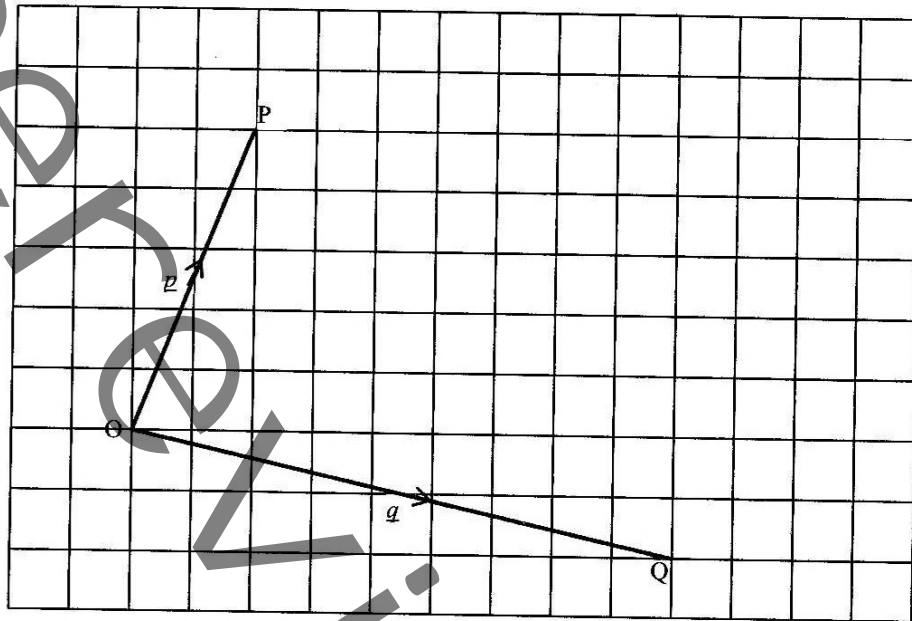

[2]

- 7 The first and second terms of an arithmetic progression are 100 and 95, respectively. Find the
- tenth term,
  - sum of the first ten terms.  $\left( S_n = \frac{n}{2} [2a + (n-1)d] \right)$

Answer: (a) ..... [1]

(b) ..... [2]

8 (a) There are 45 green and red marbles in a bag. Given that the probability of choosing a green marble is  $\frac{2}{5}$ , calculate the number of green marbles in the bag.

(b) The base areas of two containers that are geometrically similar are  $80\text{cm}^2$  and  $180\text{cm}^2$ , respectively. If the capacity of the larger container is 54 litres, calculate the capacity of the smaller one.

Answer: (a) ..... [1]

(b) ..... [2]

9 (a) Mogadishu and Kinshasa are on longitudes  $45^\circ\text{E}$  and  $15^\circ\text{E}$  respectively. If it is 11 30 hours in Mogadishu, what time is it in Kinshasa?

(b) What is the shortest distance over the Earth's surface between A( $32^\circ\text{N}$ ,  $8^\circ\text{W}$ ) and B( $40^\circ\text{N}$ ,  $172^\circ\text{E}$ )? [ $R = 6370\text{km}$ ,  $\pi = \frac{22}{7}$ ]

Answer: (a) ..... [1]

(b) ..... [2]

- 10 (a) The length of a wire is 5.2cm, correct to 1 decimal place. What is its maximum possible length?
- (b) The dividend due on 1 000 shares at the end of a financial year is K2 250.00. If the annual dividend rate is 3% of the share value, calculate the value of each share.

Answer: (a) ..... [1]

(b) ..... [2]

- 11 (a) Find the gradient of the straight line whose equation is  $3y + x = 5$ .
- (b) The diagram in the answer space below shows triangle **P** on the Cartesian plane. Given that triangle **P** is mapped onto triangle **Q** by a reflection in the line  $y = -x$ , draw and label triangle **Q**.

Answer: (a) ..... [1]

(b)

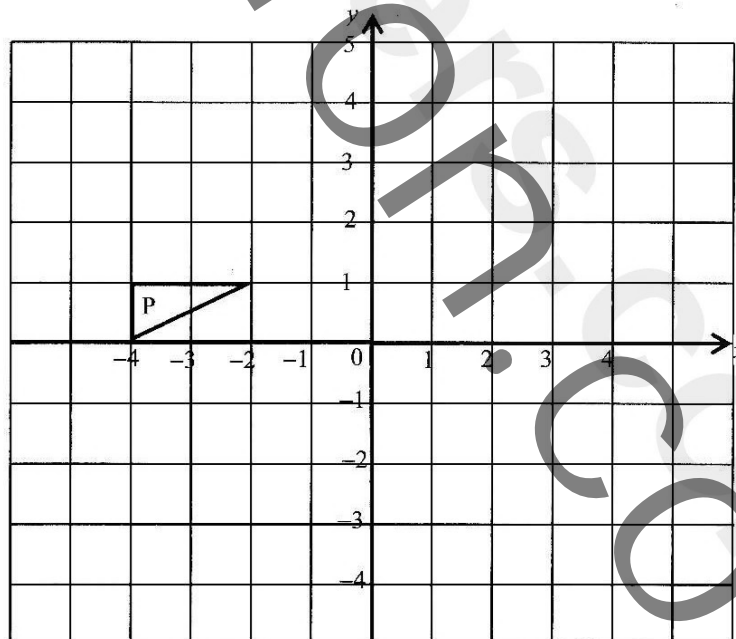

[2]

12 (a) Factorise completely  $km - 6ln + 3kn - 2lm$ .

(b) In the diagram below, MN is an arc of a circle whose centre is O and radius 21cm.

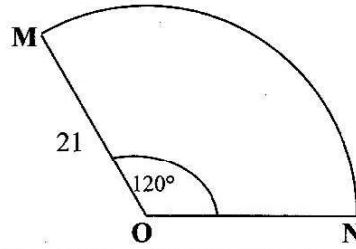

Given that  $\widehat{MON} = 120^\circ$ , calculate the area of the sector MON.

[Take  $\pi$  to be  $\frac{22}{7}$ ]

Answer: (a) ..... [2]

(b) ..... [2]

13 (a) Find the transpose of the matrix  $\mathbf{B} = \begin{pmatrix} 4 & -1 \\ 2 & 5 \end{pmatrix}$ .

(b) Find the percentage error of the mass of a bag of sugar that weighs 10.00kg, correct to 2 decimal places.

Answer: (a) ..... [2]

(b) ..... [2]

- 14 (a) Given that  $E = \{a, b, c, d, e, f, g, h\}$ ,  $A = \{a, b, c, d\}$  and  $B = \{b, c, d, e, f\}$ , list  $(A \cup B)'$ .
- (b) Find the equation of the straight line passing through  $(-4, 4)$  and is perpendicular to the straight line whose equation is  $y + \frac{x}{7} = 1$ .

Answer: (a) ..... [1]

(b) ..... [3]

- 15 The diagram below shows an equilateral triangle  $ABC$ .  $A$  is due North of  $B$  and  $CN$  is parallel to  $BA$ .

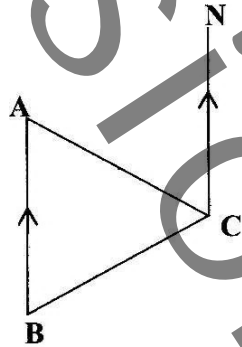

- Find (a)  $\hat{BCN}$ ,  
(b) the bearing of  $C$  from  $A$ .

Answer: (a) ..... [2]

(b) ..... [2]



16 Given that  $f(x) = \frac{5x+4}{5}$  and  $g(x) = x - 1$ ,

Find

- (a)  $f^{-1}(x)$ ,
- (b)  $f^{-1}(-2)$ ,
- (c)  $fg(x)$ , in its simplest form.

Answer: (a) ..... [1]

(b) ..... [1]

(c) ..... [2]

- 17 (a) Evaluate  $5^0 + 5^1$ .
- (b) In the answer space below, is an incomplete simple program pseudocode for calculating and outputting the volume of a cylinder  $V$ , given the base radius  $r$  and the height  $h$ . complete the program by filling in the blank spaces with appropriate statements.

**Answer:**

(a) ..... [2]

(b) Begin  
 Enter..... ;  
 $V =$  ..... ;  
 Output  $V$ ;  
 End. [2]

- 18 (a) Find  $\int (6x^2 - 5) dx$ .
- (b) The diagram below shows triangle PQR in which  $PQ = 12\text{cm}$ ,  $QR = 10\text{cm}$  and  $\hat{PQR} = 150^\circ$ .

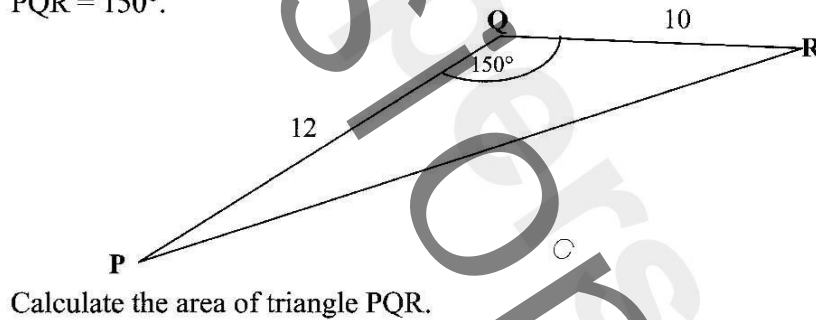

**Answer:**

(a) ..... [2]

(b) ..... [2]

- 19 In the diagram below, PR is a diameter of a circle with centre O. Q and S are points on the circumference. The tangent to the circle at the point P meets QS produced at T,  $\widehat{PQS} = 26^\circ$  and  $\widehat{QPR} = 42^\circ$ .

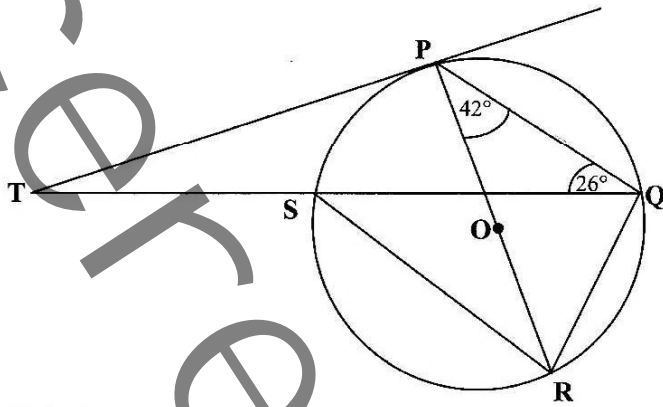

Calculate

- (a)  $\widehat{PRS}$ ,
- (b)  $\widehat{PRQ}$ ,
- (c)  $\widehat{PTQ}$ .

- Answer: (a) ..... [1]  
 (b) ..... [1]  
 (c) ..... [2]

20 It is given that  $w$  varies directly as the square of  $x$  and inversely as  $y$ .

- (a) Write an expression for  $w$ , in terms of  $x$ ,  $y$  and a constant  $k$ .
- (b) If  $x = -6$ ,  $y = 12$  and  $w = 15$ , find  $k$ .
- (c) Find the value of  $y$  when  $x = 8$  and  $w = 20$ .

Answer: (a) ..... [1]  
(b) ..... [1]  
(c) ..... [2]

21 On the XOY plane below, region R is unshaded.

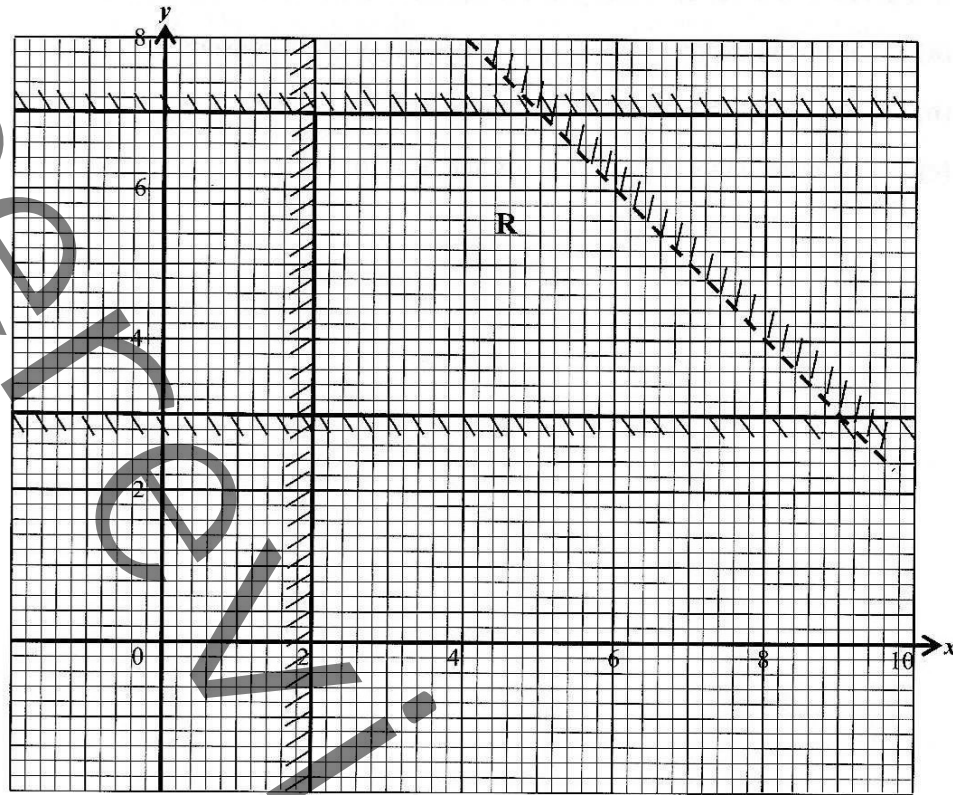

Write the four inequalities that define the region R.

Answer:

.....  
 .....  
 .....

[5]

- 22 (a) Solve the equation  $x^2 = 3x$ .
- (b) The diagram below shows a sketch of the graph of  $y = 3 - 2x - x^2$ , passing through P, Q and R.

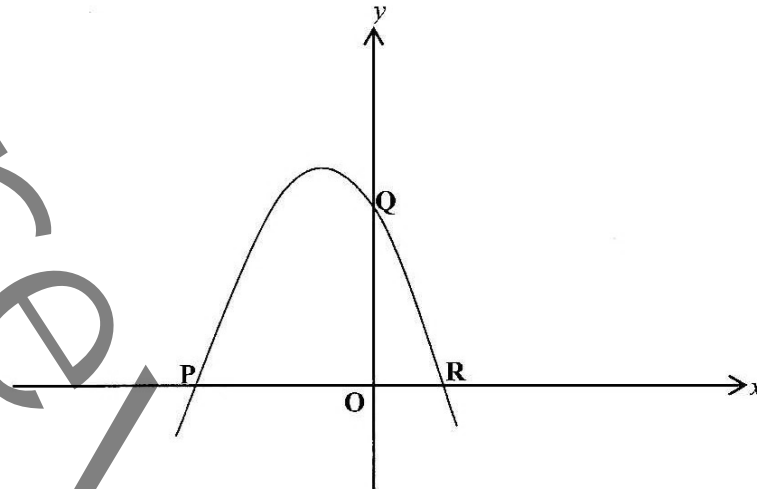

Find the

- (i) equation of the axis of symmetry of the graph,
- (ii) coordinates of the turning point of the graph.

Answer: (a)  $x = \dots\dots\dots$  or  $\dots\dots\dots$  [2]

(b) (i)  $\dots\dots\dots$  [2]

(ii)  $\dots\dots\dots$  [2]

- 23 The diagram below is the speed-time graph of a particle. The particle accelerates uniformly from a speed of  $v$  m/s to a speed of  $5v$  m/s in 20 seconds.

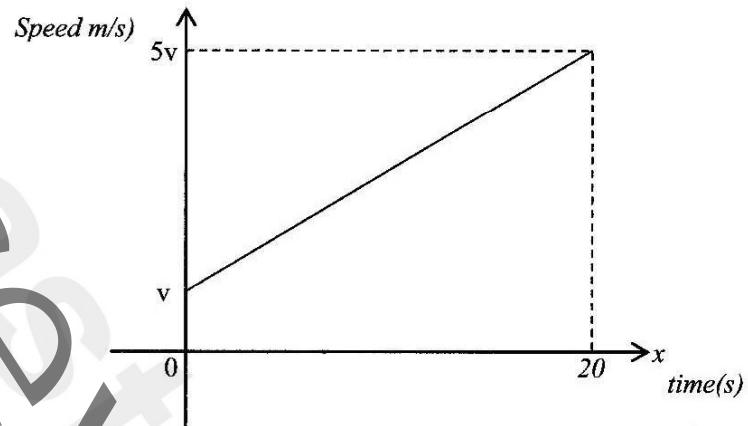

- (a) Find an expression in terms of  $v$ , for acceleration.
- (b) The distance travelled by the object from 0 seconds to 20 seconds is 80m. Find the value of  $v$ .
- (c) Find the speed at  $t = 15$  seconds.

**Answer** (a) ..... [1]  
 (b) ..... [2]  
 (c) ..... [3]