



JUNE XXXX

INTERMEDIATE LEVEL

Subject Title	ELECTRONIC CIRCUITS
Subject Code No.	5255
Paper No.	THREE

Duration: Four Hours

Answer all the questions.

All drawings must be neat, clear and drawn to scale.

You are allowed the use non programmable calculators and mathematical sets.

You are reminded of the necessity for good English and orderly presentation in your answers.

Turn Over

TITLE: MONITORING OF LIQUID LEVEL

You are required to realize the printed circuit of the liquid level monitoring represented in figure 1 below.

Work required

A- You are required to draw the printed circuit of the device using an A4 tracing paper; the size of the printed circuit should be reduced to minimum. In drawing the printed circuit, you are required to use the international grid and the following aspects must be respected:

- Maximum dimension of the printed circuit: 80 x 50mm².
- In folding the tracing paper used in drawing the printed circuit, the two plans have to be superimposed (the copper and the component sides)

B- Establish the nomenclature of the components in a table format which should include:

- Letter symbol
- Component name
- Type
- Nominal voltage
- Rated value
- Power rating
- Tolerance
- Observation

C- Marking scheme

- | | |
|--|----------------------------|
| - Printed circuit well drawn | +20 marks |
| - Problems in circuit due to | |
| • Polarity inversion | -2 marks/component |
| • Wrong localization | -0.5 mark/component |
| • Inadequate linking of strip | -3 marks/link |
| • Omission of a component | -4 marks/component |
| • Respect of the dimension of components | +7 marks |
| • Respect of cir circuit drawing rules (angles), solder joints etc | +7 marks |
| • Nomenclature | +8 marks |
| • Optimization of the area | +7 marks |

Each candidate is supplied with an A4 tracing paper and should use a maximum size of 80 x 50mm.

CIRCUIT DIAGRAM

Figure 1

Dimensioning of the Components

Resistors: R1 to R6

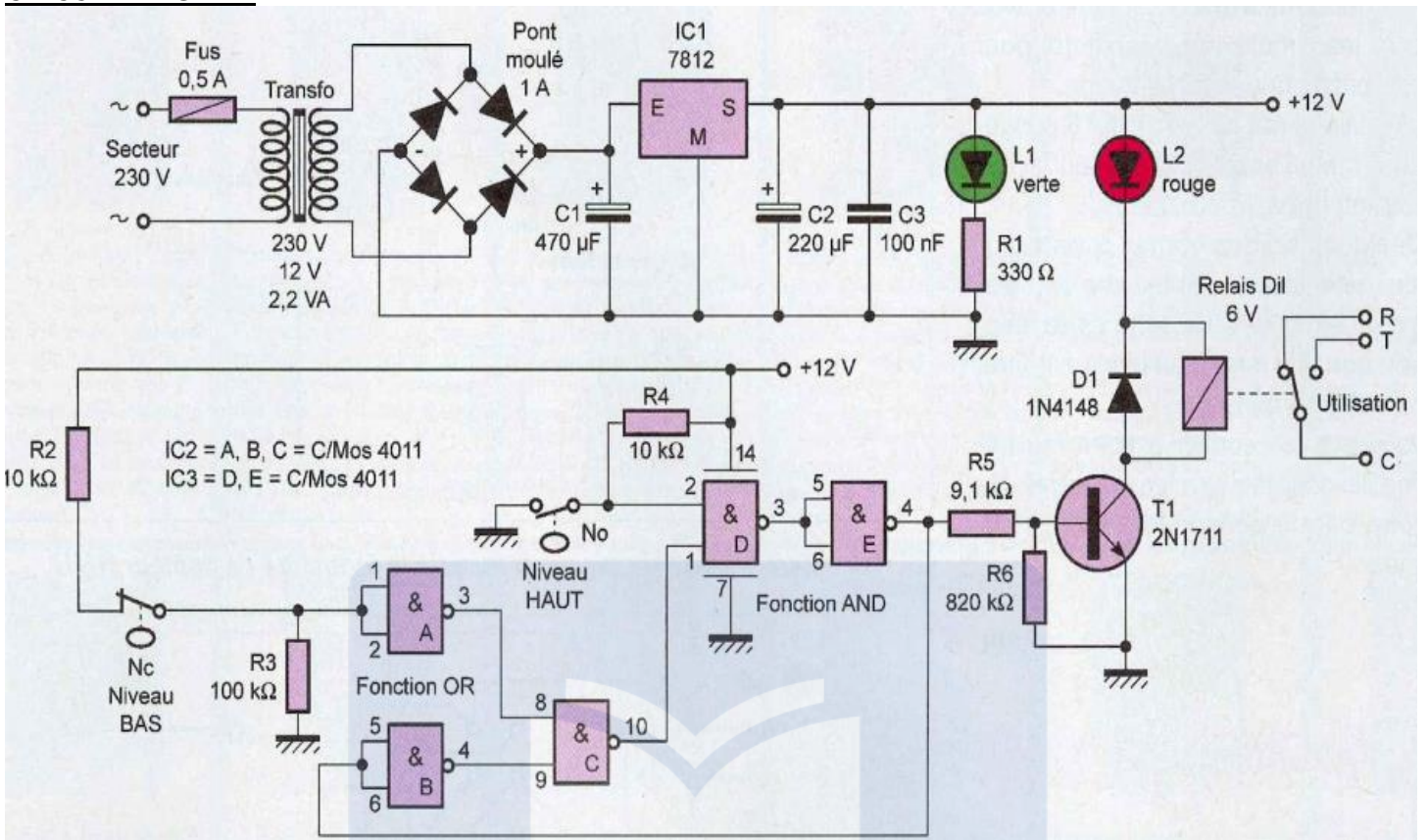
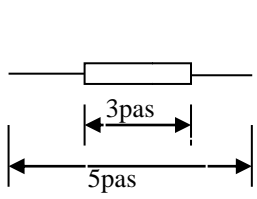

CAPACITOR: C1

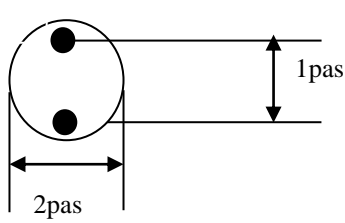

Transformer

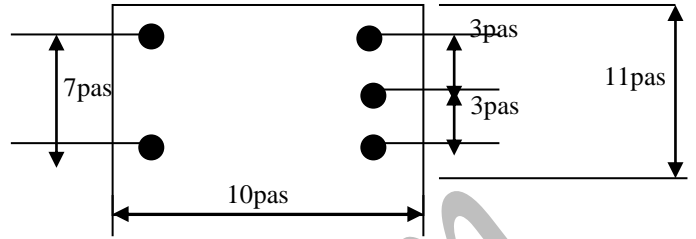

CAPACITORS: C1, C2 ;

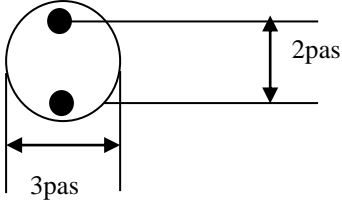

RELAY : RL

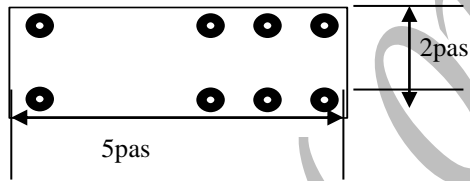

TRANSISTORS : T1

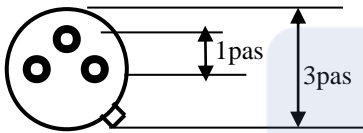

LEDs(L1 ; L2)

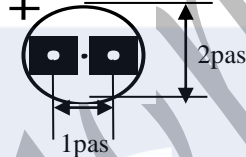

DIODE :D1

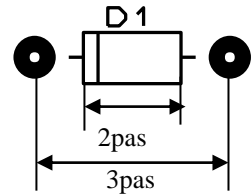

Bridge rectifier :

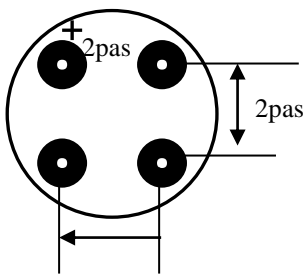

INTEGRATED REGULATOR

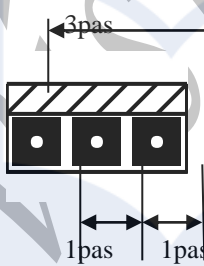

TERMINALS

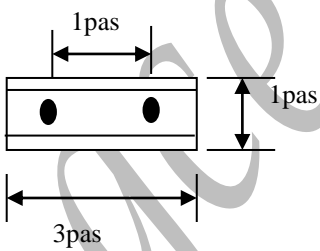

INTEGRATED CIRCUIT : IC1

