



Technical and Vocational Education Examinations

CARPENTRY 3  
5495

JUNE XXXX

INTERMEDIATE LEVEL

Subject Title	<b>CARPENTRY</b>
Subject Code No.	<b>5495</b>
Paper No.	<b>THREE</b>

SEE QUESTION INSIDE

All dimensions are given in millimeters

This paper shall be evaluated on **80 marks**.

---

**4 HOURS**

**INSTRUCTIONS TO CANDIDATES**

1. Candidates must **PROVIDE** all the working required
  2. The examination is schedule for four continuous working hours.
  3. Candidates shall commence work at 8:00 am.
  4. The interchanging of aid between the candidates shall not be allowed.
  5. All Examination Materials shall **NOT** be carried home before the end of the examination
  6. This paper is weighted as 40% of the total subject marks.
- **You are reminded of the necessity for good English and orderly presentation in your answers.**

---

*Turn Over*

## DESCRIPTION

The working drawing below represents **wooden Floor** with an opening to be constructed out of Iroko seasoned approximately to 12% moisture content.

The frame consists of solid wood assembled using housing and corner rebate joints. The floor boards are joined with T&G joint.

### Question

Carefully produce a prototype which will be tested to confirm or re-dimension the pieces. (part "B" only)

### CUTTING LIST PER CANDIDATE

SN <sup>o</sup>	QUALITY	LENGTH	WIDTH	THICKNESS	SPECIES
1.	2	400	80	35	Iroko of About 12% mc
2	2	600	80	35	
3	1	480	80	35	
4	1	350	80	35	
5	4	50	80	10	Provide T&G

### OTHER MATERIALS

SN <sup>o</sup>	ITEM	QUANTITY	SPECIFICATION
01	Nail	20	Nail 60
02	Nail	20	Power pin
03	Glue	25kg	Vinyl glue
04	abrasive	2 sheets	P80 & P 100

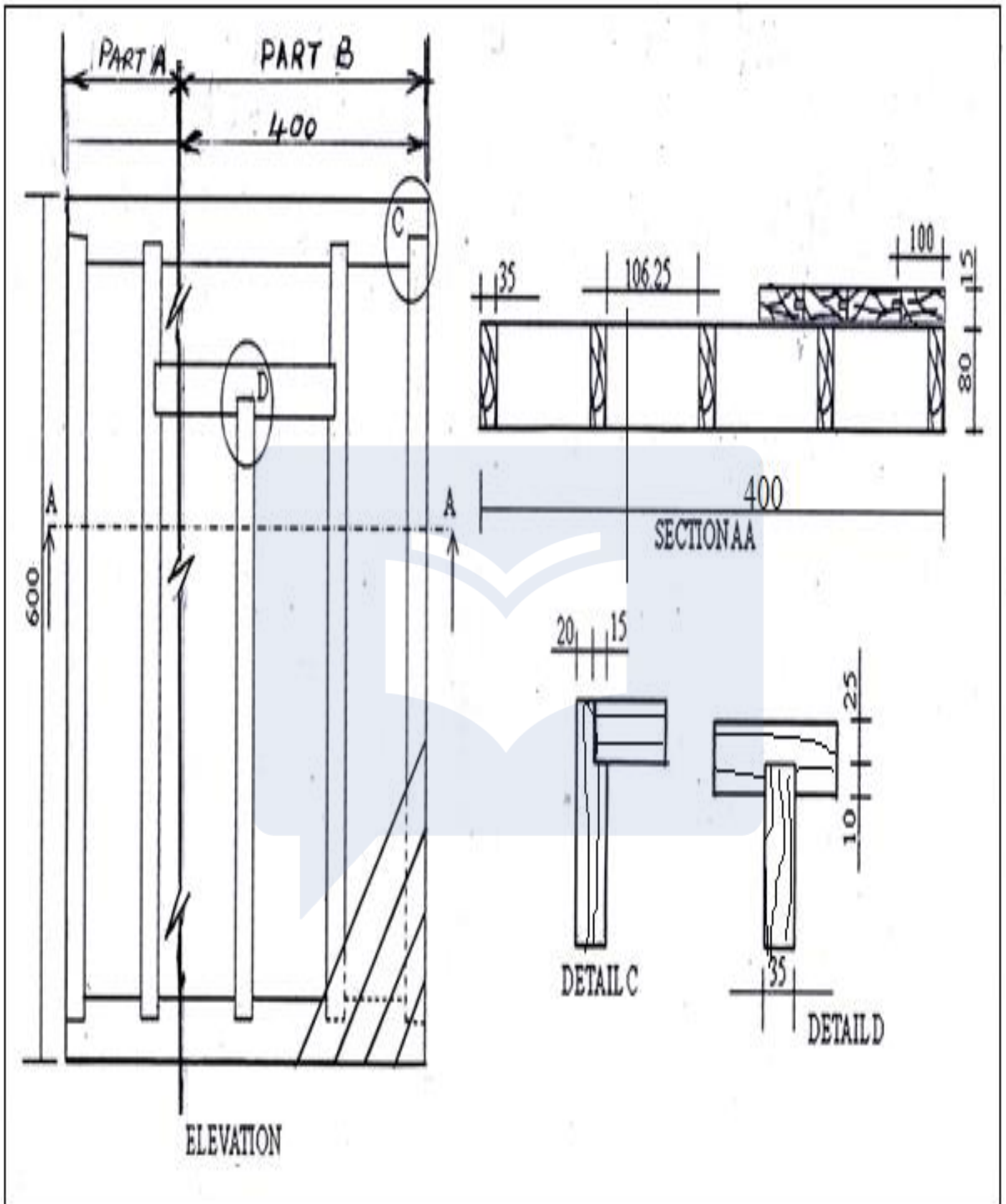

## CAMEROON GENERAL CERTIFICATE OF EDUCATION BOARD

## Technical and Vocational Education Examinations

June.....

INTERMEDIATE LEVEL

**MARKING GUIDE**

CENTRE NO.....CENTER NAME.....

NAME OF CANDIDATE .....

CANDIDATE N<sup>o</sup>.....CODE N<sup>o</sup>.....

RUBRICS		MARKS		SCORE			
DIMENSION	600X400	10	10	8	6	4	2
	SPAN:106.25	12	12	9	6	3	1
JOINTS	CORNER REBATE	10	10	8	6	4	2
	HOUSING	20	20	15	10	5	2
	FLOOR BOARDS	12	12	8	6	4	2
GENERAL ASPECT	SQUARENESS	6	6	4	3	2	1
	STABILITY	5	5	4	3	2	1
	SOLIDITY	5	5	4	3	2	1
	<b>TOTAL</b>	<b>80</b>					

## CAMEROON GENERAL CERTIFICATE OF EDUCATION BOARD

**Technical and Vocational Education Examinations**

## ADVANCED INFORMATION TO THE CENTRE

June.....

INTERMEDIATE LEVEL

**CUTTING LIST PER CANDIDATE**

SN <sup>o</sup>	QUALITY	LENGTH	WIDTH	THICKNESS	SPECIES
1.	2	400	80	35	Iroko of
2	2	600	80	35	About 12%
3	1	480	80	35	mc
4	1	350	80	35	
5	4	50	80	10	Provide T&G

**OTHER MATERIALS**

SN <sup>o</sup>	ITEM	QUANTITY	SPECIFICATION
01	Nail	20	Nail 60
02	Nail	20	Power pin
03	Glue	25g	Fast drying synthetic glue
04	abrasive	2 sheets	P80 & P 100

## CAMEROON GENERAL CERTIFICATE OF EDUCATION BOARD

**Technical and Vocational Education Examinations**

## ADVANCED INFORMATION TO THE CENTRE

June.....

INTERMEDIATE LEVEL

**LIST OF TOOLS**

- Hand plane
- Cross-cut saw
- Rip saws
- Chisels (flat, assorted sizes)
- 2 Sash cramps of 1m
- Measuring tape
- Set of firmer chisel
- Rasp ( semi-circular, flat)
- Claw hammer
- Pair of pincers