

**GENERAL CERTIFICATE OF EDUCATION BOARD**

Technical and Vocational Education Examination

**CHASSIS SYSTEMS AND TRANSMISSION 2**

7130

**JUNE 2022**

**ADVANCED LEVEL**

Specialty Name and Acronym	<b>AUTOMOBILE CONSTRUCTION AND MAINTENANCE: LIGHT VEHICLE (AM-LV)</b>
Subject Title	<b>CHASSIS SYSTEMS AND TRANSMISSION</b>
Subject Code No	<b>7130</b>
Paper No.	<b>2</b>

**Duration: 3 Hours**

**INSTRUCTIONS TO CANDIDATES**

**This Paper has TWO Sections (A and B).**

**Section A: Answer Three Questions**

**Section B: Answer Two Questions**

**All questions carry equal marks**

**Calculators are allowed**

**You are reminded of the necessity for good English and orderly presentation in your answers.**



**Turn Over**

**SECTION A**  
(Answer **THREE** questions from this Section)

**1. CLASSICAL GEARBOX**

Figure 1 below shows a typical layout of a conventional gearbox.

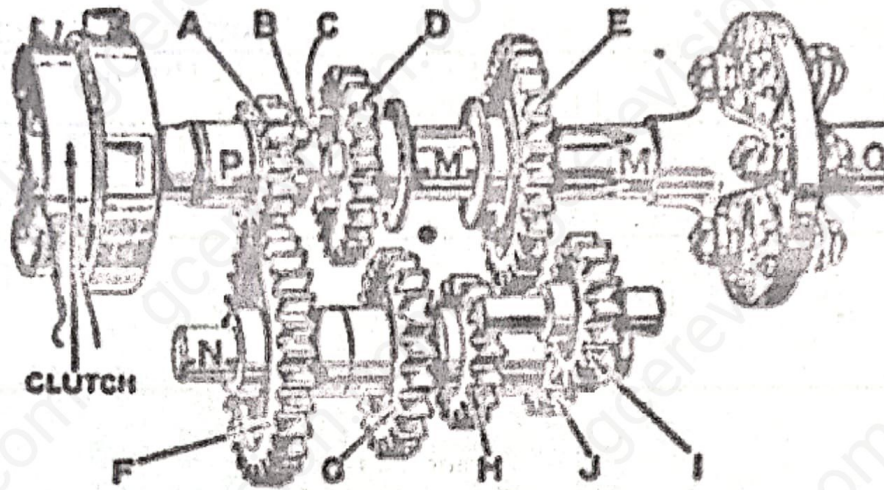

**Figure 1**

- a. Identify the type of gearbox and the number of gears that can be selected. (1.5x2marks)
- b. Reproduce the table below and give the names and function of the following organs; P, N, M and I (3marks)

Ref	Name (0.25x4marks)	Function (0.5x4marks)
P		
N		
M		
I		

- c. At the phase shown in figure 1, which gear is engaged? Justify your answer. (1.5marks)
- d. Explain how the reverse gear is obtained in this gearbox. (2.5marks)
- e. Carefully examine the gearbox and say how many selector forks are used to perform gear change. (1.5mark)
- f. Show by means of a sketch the provision that is made in this gearbox to prevent the accidental selection of reverse during gear changing. (2.5marks)
- g. The spur gear (a), the helical gear (b) and the double helical gear (c) are all types of gears used in gearboxes. Reproduce and complete the sketches in figure 2 showing the teeth arrangement for each type. (2x3marks)



(a)

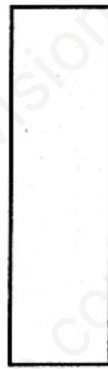

(b)



(c)

**Figure 2**

**2. SUSPENSION, ROAD WHEELS AND TYRES**

Figure 3 shows the layout of a vehicle suspension system.

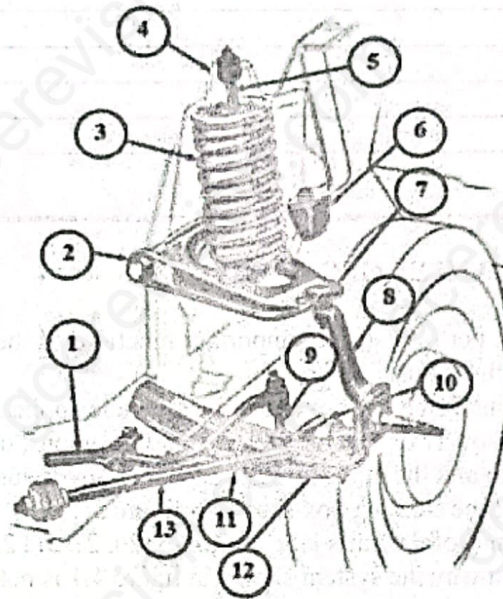
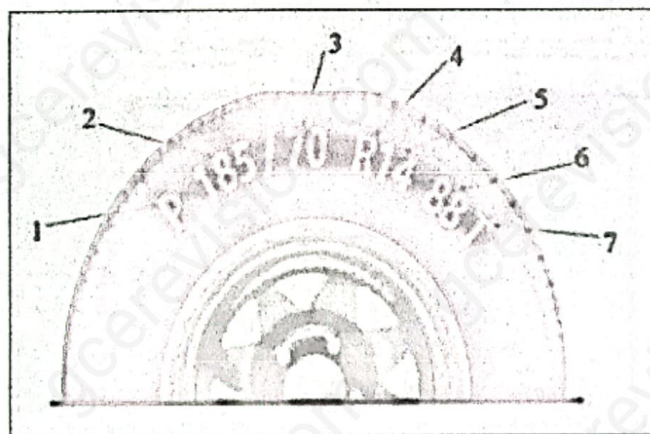

**Figure 3**

- a. Identify the type of suspension layout. (1mark)
- b. Reproduce and complete the table by giving the organs and their respective functions in your answer booklet. (5marks)

Ref	Name (0.5x5marks)	Function (0.5x5marks)
1		
3		
4		
5		

- c. What are suspension bushings? (1marks)
- d. State TWO problems caused by worn suspension bushings. (2marks)
- e. Briefly explain how the element 1 operates during movement of the suspension system. (2marks)
- f. Suspension problems increase tyre wear and may require an interchanging of tyres. Why is this done. (2marks)
- g. Figure 4 is a pictorial view of a vehicle tyre. Given the tyre characteristics with the corresponding numbers on the figure, fill the table below in your booklet. (7marks)



**Figure 4**

Turn over

Ref	Designation (1x7marks)
1	
2	
3	
4	
5	
6	
7	

### 3. STEERING AND FRONT WHEEL GEOMETRY

- a. The steering system must perform several important functions as the vehicle is being driven. Give any TWO of these functions. (1mark)
- b. Name TWO types of manual steering boxes for light vehicle application that you know. (1mark)
- c. The figures 5.1 and 5.2 show two types of steering configurations, one for a rigid or solid axle type of suspension system and the other for an independent front suspension system.
- Give the name of the steering box shown in figure 5.1. (1mark)
  - What are the names of the parts labeled 3, 4, 5, 20, 21 and 23 in figure 5.1. (1.5mark)
  - Give ONE reason why the system shown in figure 4.1 is not suitable for a rigid axle type of suspension system. (1mark)
  - Indicate which component on figure 5.1 should be altered when
    - adjusting the backlash between the rack and pinion gear teeth and (1mark)
    - adjusting toe-in or toe-out of the front steered wheels. (1mark)
  - What type of periodic maintenance will you carry out on the system in figure 5.1? (1marks)
  - Name the parts labeled 1, 2, 3, 5 and 6 in figure 5.2. (1.25mark)

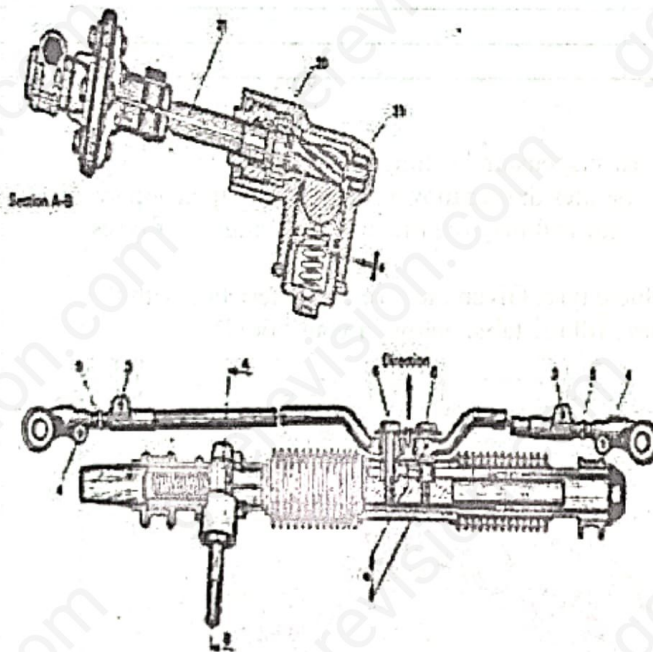

Figure 5.1

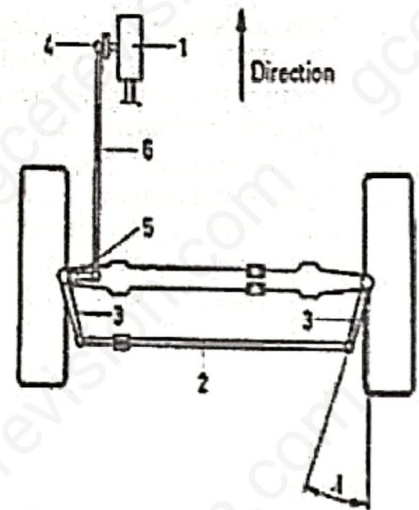

Figure 5.2

d. Power assisted steering system.

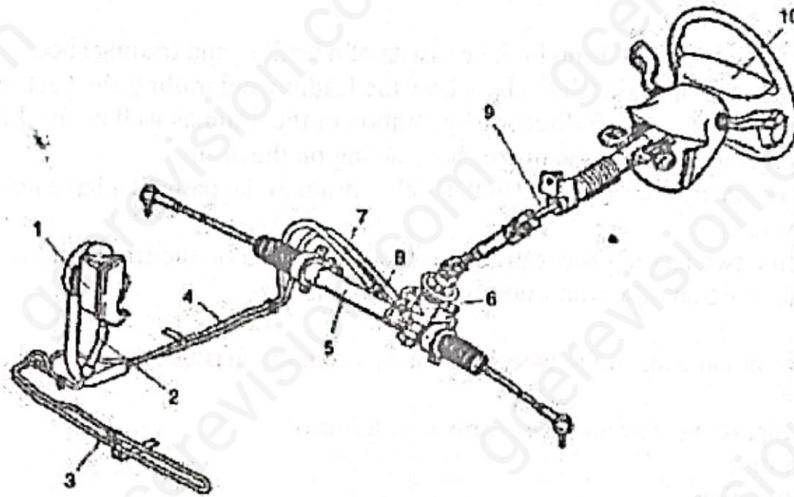

Figure 6

- i) Give TWO reasons for fitting a power assisted steering on a vehicle. (2marks)
- ii) Briefly explain the term **fail safe** in relation to power assisted steering systems. (1mark)
- iii) Give the names as well as the functions of the parts labeled 2, 3, 4, 5, 6, 7 and 9 in the system. (1.25mark)
- iv) At what period does a power assisted steering come into operation? (1mark)
- v) Name FOUR components of the system shown in figure 6 that require regular check. (2marks)
- vi) What symptom will manifest if air is trapped in the hydraulic line of this system and how can one bleed the circuit? (1mark)
- vii) What are the differences between the power assisted steering system shown in figure 6 and the
  - i) **electric type** of power assisted steering? (1marks)
  - ii) **electrohydraulic type** of power assisted steering systems? (1marks)

#### 4. BODY DESIGN

- a. In vehicle construction, one always comes across terms like the **vehicle body, vehicle frame**. Is there any difference between the vehicle frame and the vehicle body? Justify your answer with a summarized appropriate explanation in at least three lines. (4marks)
- b. Define the following terms related to vehicle construction and body design.
  - i) Unit-body construction (2marks)
  - ii) Body-on-frame vehicle construction (BOF). (2marks)
- c. Name TWO types of stresses the vehicle frame is subjected to during diverse driving conditions. (2marks)
- d. In designing vehicle bodies, "**crumple zones**" are provided at the front and rear of the vehicle. Explain in four lines what is referred to as "**crumple zones**" and give the reason why they are put in place during vehicle construction. (4marks)
- e. Prescribe the precaution used to protect the vehicle's structure from corrosion. (2marks)
- f. In THREE lines explain how the shape of a vehicle's body design can affect fuel consumption. (4marks)

## 5. BRAKES

- a. A hydraulically operated drum brake consists of a leading and trailing shoe.
- Make a simple sketch to show how the leading and trailing shoe act in the brake drums. Clearly indicate the direction of rotation of the drum as well as the direction of the frictional forces of the brake shoes acting on the drum. (4marks)
  - Write down the names of FOUR other drum brake parts that have not been mentioned above. (2marks)
- b. State why the two leading shoes arrangement is preferred on the front wheels to the rear wheels. (2marks)
- c. What is the function of a proportioning valve. (2marks)
- d. Describe what happens in the wheel assembly when the master cylinder builds up pressure in the brake lines. (4marks)
- e. Briefly compare the disc and drum brakes in terms of;
- Output (2marks)
  - Operation (2marks)
- f. Give TWO reasons why the disc brake is preferred at the front wheels than at the rear wheels. (2marks)

## SECTION B

(Answer TWO questions from this Section)

## 6. BRAKES AND LEVERAGE

a.

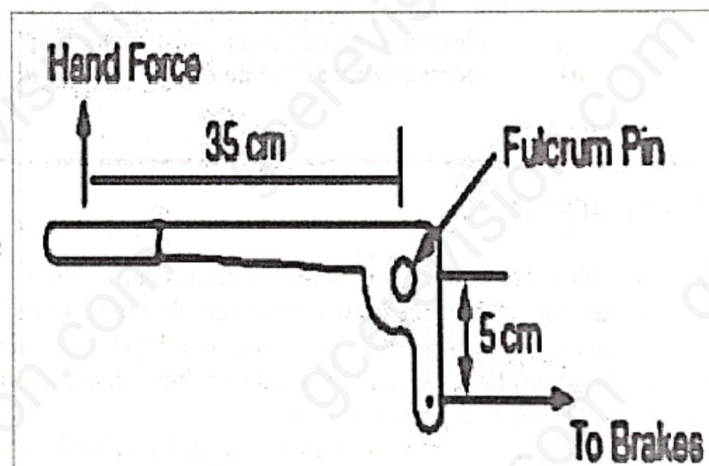
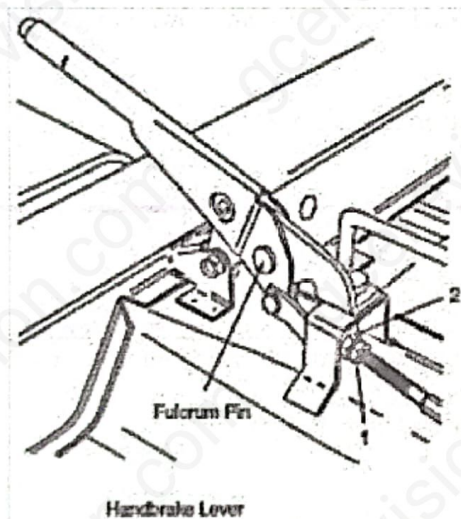

Figure 7

In the hand brake lever mechanism shown in figure 7, a brake cable force of 420N is required to apply the brakes. Calculate the hand force applied at right angles to the long part of the lever that is required to produce this force in the cable.

(2marks)

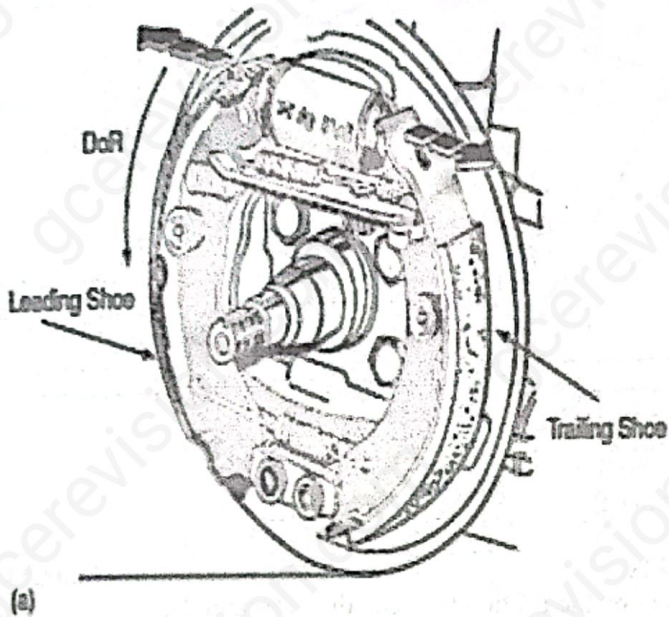

Figure 8a

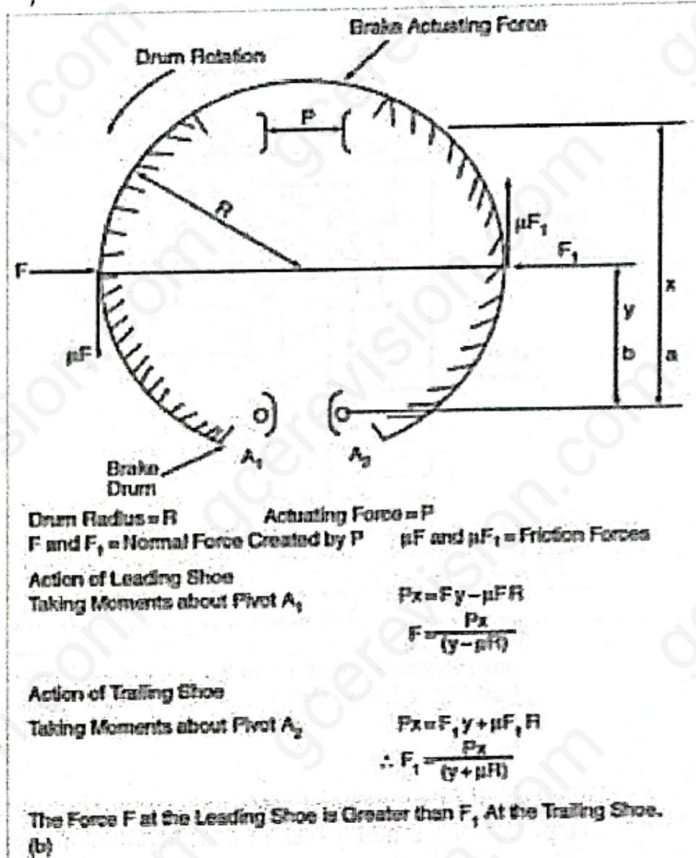

Figure 8b

Figure 8

In a drum brake arrangement, the distance  $x$  is as shown in figure 8b is 12cm, the distance  $y$  is 24cm and the drum radius  $R = 14$ cm. If the actuating force  $P$  is 800N and the coefficient of friction  $\mu = 0.4$ .

- i) Calculate the effective friction of force on each of the brake shoes. (4marks)
  - ii) What is the disadvantage of a leading shoe drum brake arrangement when reversing the vehicle in terms of effective braking? (2marks)
- b. In a disc of the type shown in figure 9 the hydraulic pistons are 50mm in diameter and the effective radius of the brakes disc is 150mm. Calculate the braking torque when the hydraulic pressure is 20bar and the coefficient of friction is 0.4. (3marks)

Turn over

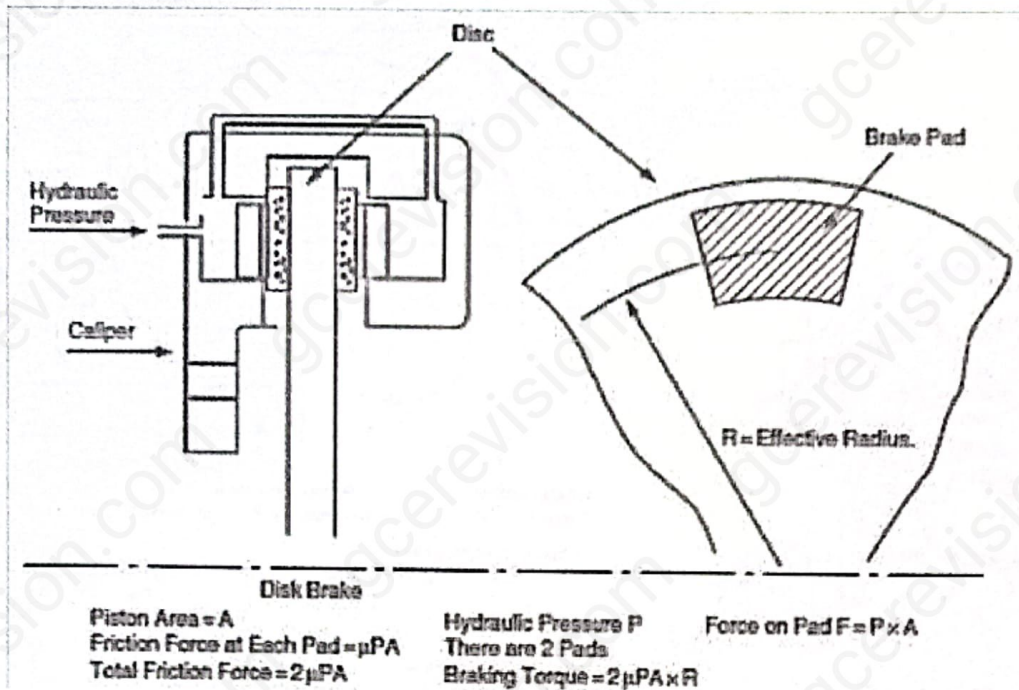

Figure 9

- c. Give FOUR advantages of disc brakes over drum brakes. (4marks)
- d. The power of a braking system is determined ultimately by the friction between the tyres and the driving surface. The concept of braking efficiency is based on the assumption that the coefficient of friction between the tyre and driving surface can never be greater than 1.

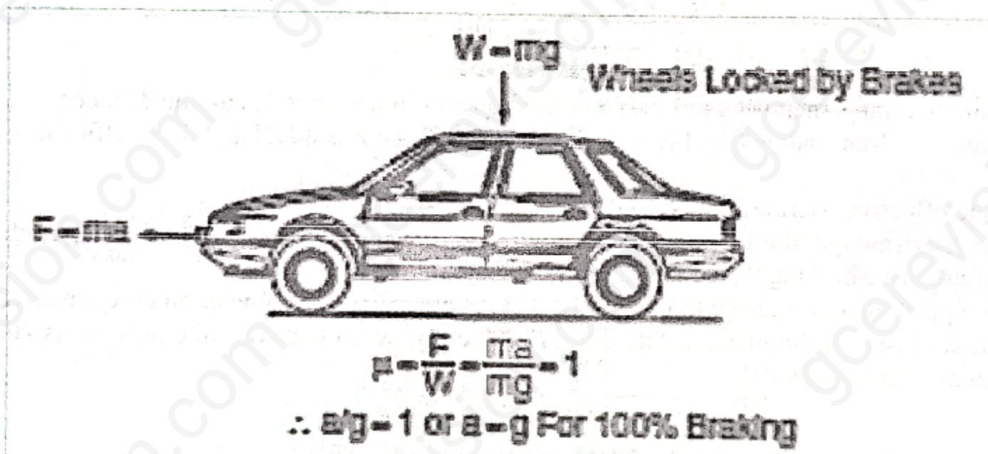

Figure 10

The maximum braking deceleration of a vehicle is  $7.2 \text{ m/s}^2$ . Calculate the braking efficiency. Take  $g = 9.81 \text{ m/s}^2$

- c. In a test station brake-test on a vehicle (figure 11), the front brake forces total 1400N. If the vehicle has a mass (weight) of 1.2 tons, calculate the braking efficiency. Take  $g = 9.81 \text{ m/s}^2$ . (2marks)
- (3marks)

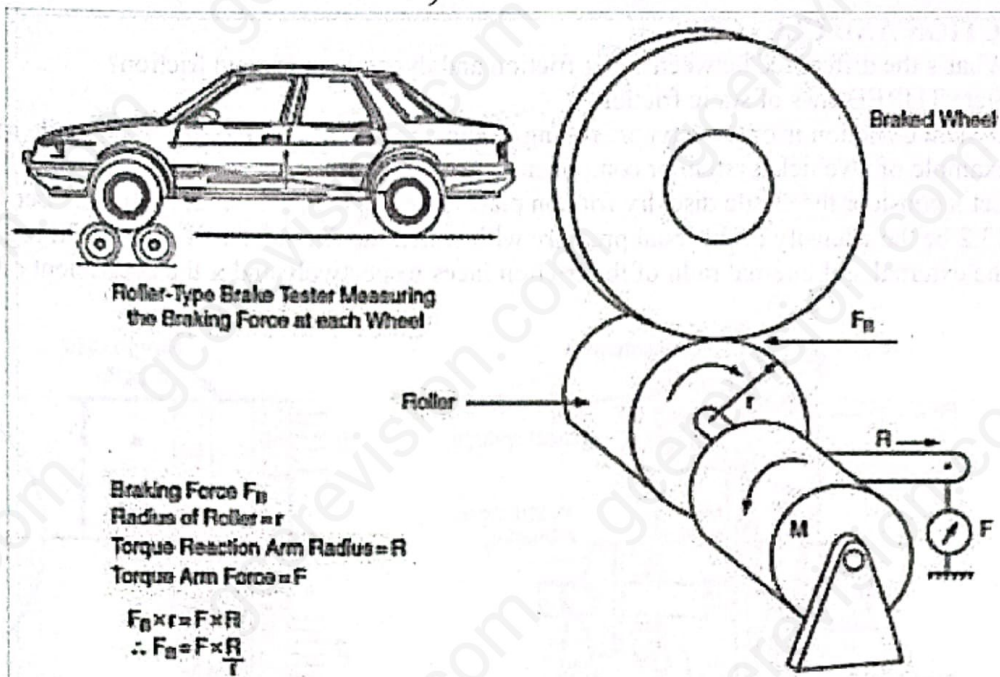

Figure 11

## 7. HYDRAULICS

Figure 12 below is a hydraulic layout of the braking system. The master cylinder piston diameter is 23mm, front wheel piston diameter is 58mm, rear wheel piston diameter is 33 mm, A is 220 mm, B is 60 mm and the driver effort exerted on the pedal is 30 N.

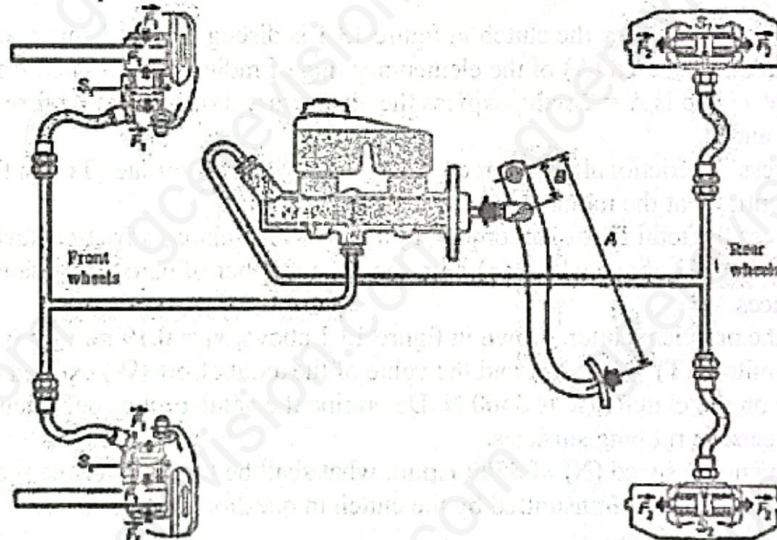

Figure 12

- Explain what is meant by:
  - The principle of moment. (2marks)
  - The principle of Pascal Law. (2marks)
- Calculate the force applied on the master cylinder piston. (2.5marks)
- Calculate the sectional area:  $S$ ,  $S_1$  and  $S_2$ . (1.5x3marks)
- Calculate the circuit pressure. (3marks)
- Calculate the force  $F_1$  applied on the front disc. (1.5marks)
- Calculate the force  $F_2$  applied on the rear drum. (1.5marks)
- Deduce the pedal and hydraulic ratios. (1.5x2marks)

Turn over

## 8. FRICTION AND CLUTCHES

- a. What's the difference between static friction and dynamic or kinetic friction? (2marks)
- b. State THREE laws of static friction. (3marks)
- c. Dynamic friction is of three types; sliding, rolling and pivot. Define each type while giving one example of a vehicle system or component where it occurs. (3marks)
- d. Let's consider the single disc dry friction plate clutch system shown in figure 13. Let  $P$  in figure 13.2 be the intensity of the axial pressure with which the friction surfaces are held together,  $r_1$  and  $r_2$  the external and internal radii of the friction faces respectively and  $\mu$  the coefficient of friction.

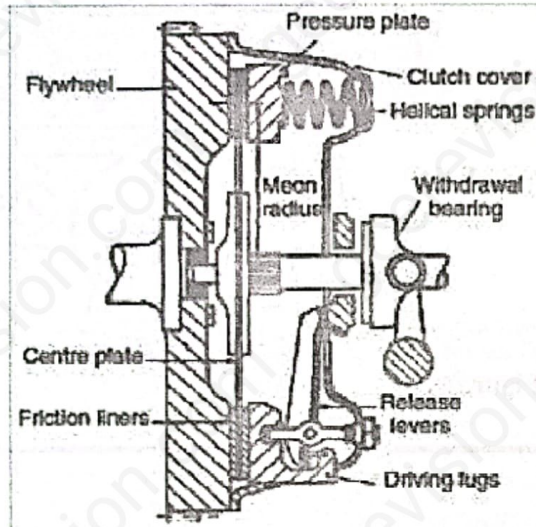

Figure 13.1

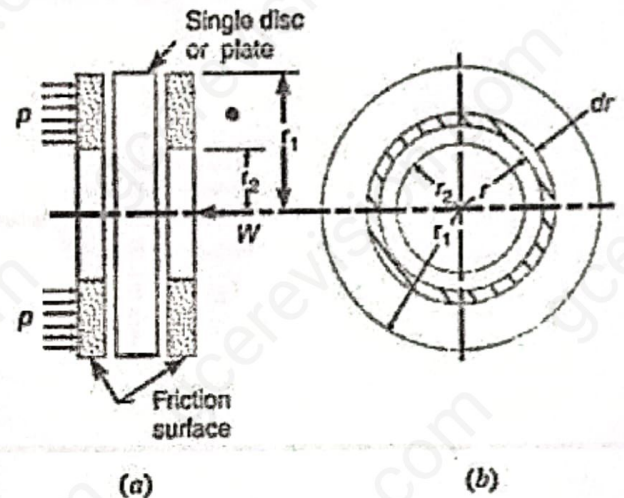

Figure 13.2

- i) Briefly explain how the clutch in figure 13.1 is disengaged and engaged. (3marks)
- ii) Given that the area ( $A$ ) of the elementary ring of radius ( $r$ ) and thickness ( $dr$ ) in figure 13.2 b is  $A = 2\pi r dr$ , express the elementary axial or normal force  $\delta w$  in function of  $A$  and  $P$ . (1mark)
- iii) Express the frictional drag force ( $F_r$ ) and the frictional torque ( $T_r$ ) on the ring acting tangentially at the radius  $r$  in function of  $\mu$  and  $r$ . (2marks)
- iv) Express the total frictional torque ( $T$ ) acting on the clutch's friction surfaces from  $r_2$  to  $r_1$  in figure 13.2 above where ( $n$ ) represents the number of pairs of friction or contact surfaces. (2marks)
- v) For the practical clutch shown in figure 13.1 above,  $r_1 = 0.19$  m,  $r_2 = 0.14$  m, total torque transmitted ( $T$ ) = 186 Nm and the value of the axial effort ( $W$ ) exerted by the pressure plate on the clutch disc is 3400 N. Determine the value of the coefficient of friction  $\mu$  between the rubbing surfaces. (2marks)
- vi) At an engine speed ( $N$ ) of 3500 r.p.m, what shall be the value of the mechanical power ( $P_m$ ) that's being transmitted by the clutch in question (v) above? (2marks)